

Hardware Interface Description (HIF)  
for the  
DRAGON Servo Amplifier

Prepared By:

**ESIMotion**

2250A Union Pl  
Simi Valley, CA 93065

**Change History**

Version	Date	Items Changed
A		Initial Release – Based on previous ESI Doc. #100024-01D
B	08/26/10	Changed the following: <ul style="list-style-type: none"><li>• D38999/20WD35PA to D38999/20FD35AA</li><li>• Changed all connectors from olive drab to electroless nickel finish.</li></ul> Changed in both the Connector Summary and in the J3 description. Electroless nickel is called out with the “F” in the 38999 connectors and with an “L” in the MS34xx connectors.
C	3/12/11	Fixed the pinout of J2 – there was a Q listed but there was no Q in the connector.
D	12/18/12	Changed references from RS485 to RS422
E	03/28/13	Corrected CAN ISO reference, and updated logo.

## TABLE OF CONTENTS:

HARDWARE INTERFACE DESCRIPTION (HIF).....	1
1 OVERVIEW.....	4
2 MOTOR POWER J1 .....	6
3 MOTOR OUTPUT J2 .....	6
4 FEEDBACK J3 .....	8
5 SYSTEM INTERFACE (SI) .....	9
5.1 CAN.....	10
5.2 RS422.....	10
5.3 Digital Input/Outputs.....	10
5.4 Analog Input.....	10
5.5 HiDS Interface .....	11
5.6 Analog Test Points .....	11
5.7 Program Update.....	11
5.8 System Interface Connector J4.....	11
6 CONNECTOR SUMMARY .....	14
7 CONCLUSION .....	14

## 1 Overview

The following is a Hardware Interface (HIF) Description for the DRAGON. The HIF includes all information necessary to integrate the DRAGON with other system components. The HIF includes information on the electrical interface as well as the physical interface.

The HIF is designed to be generic and easily adapted to different applications. In order to design a multi-use capability, networking has been emphasized in the DRAGON. The DRAGON can be connected to the following two types of networks:

- RS-422
- Controller Area Network (CAN)

Both networks are ideal for real-time embedded networking. They have been proven to be stable and robust as well as flexible. Thus, the DRAGON can easily be modified through software to accept commands and report feedback without hardware modification.

This document discusses the system interconnect by functional group. The five groups are as follows:

- Motor Power
- Motor
- System Interface
- Resolver
- Service Interface

A diagram of the HIF can be seen in the Figure below.

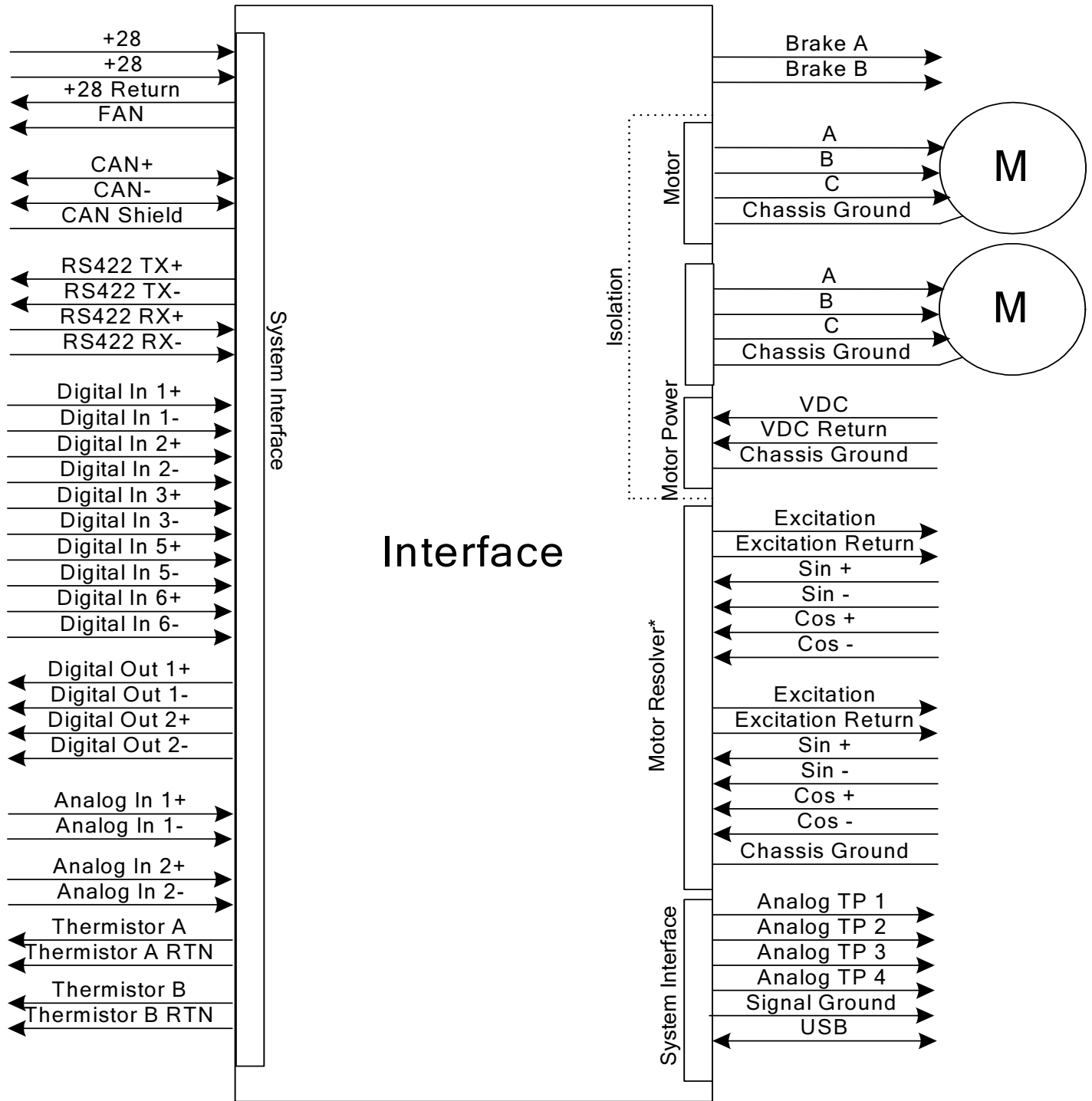

**Figure 1. Dual Axis DRAGON Hardware Interconnect Diagram**

\*Encoder Feedback also available

## 2 Motor Power J1

The motor power input is the main power input. The motor power signals are isolated from the control circuitry.

The power connector an insert arrangement 16-10, part number MS3452L16-10P. The MS3452 series features box mounting and crimped pins. The box connections are pins and they mate with a socket-type connector, part number MS3456L16-10S. See datasheet for detailed mechanical dimensions.

The pin-out of the power connector can be seen below:

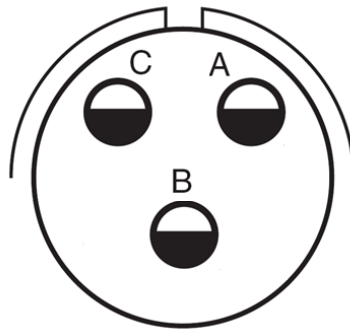

Figure 2. 16-10 Motor Power Connector (Looking into Box Connector) J1

Pin Letter	Description DC System	Description AC System	Wire Gauge	Pin Current Rating (Amps)
A	VDC	Phase A	12	23
B	VDC Return	Phase B	12	23
C	Chassis Ground (Shield)	Chassis Ground (Shield)	12	23

## 3 Motor Output J2

The motor output connector contains the following signals:

- Phase A
- Phase B
- Phase C

- Brake+
- Brake-
- Regen
- Regen Rtn
- Chassis (x2)

The motor connector is an insert arrangement 24-19. The connector part number is MS3470L24-19S. The MS3470 series features box mounting and crimped pins. The connections are sockets and they mate with a pin-type connector, part number MS3476L24-19P.

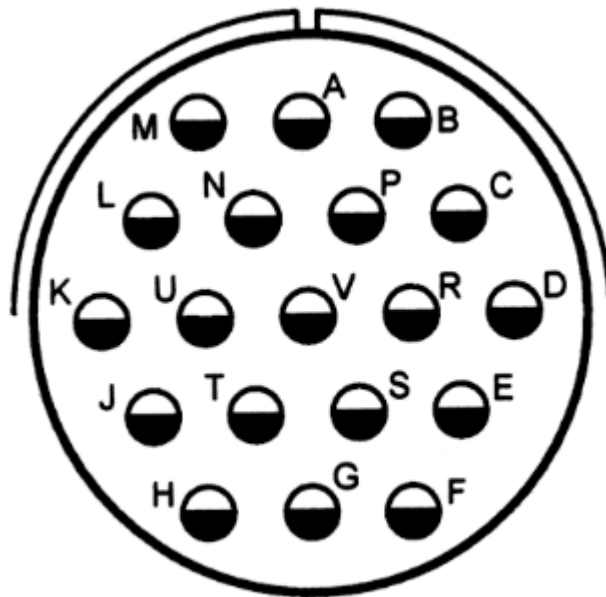

Figure 3. 24-19 Motor Connector J2

Single Axis Motor Connector Pinout			
Pin Letter	Description	Wire Gauge	Pin Current Rating
A	Motor A Phase A	12	23
B	Motor A Phase B	12	23
C	Motor A Phase C	12	23
D	Chassis Ground	12	23
E	Regen	12	23
F	Regen Rtn	12	23
G	Chassis Ground	12	23
H	Motor B Phase C	12	23

J	Motor B Phase B	12	23
K	Motor B Phase A	12	23
L	Interlock	12	23
M	Interlock Return	12	23
N	BrakeA Return	12	23
P	BrakeA+	12	23
R	BrakeB Return	12	23
S	BrakeB+	12	23
T	Unused	12	23
U	Unused	12	23
V	Unused	12	23

The DRAGON provides two 24-volt brake drivers. The brake current is nominally 1 amp and is current limited to 1.5 Amps +/- 10%.

**4 Feedback J3**

The DRAGON contains an interface for two resolvers. The resolvers are shared on a single 37-pin connector. The connector is type D38999/20FD35AA (Insert arrangement 15-35, A Clocking). It accepts a size 22D pin (AWG wire size 22-28). The connections are pins and they mate with a socket-type connector, part number JD38999/26FD35SA. See datasheet page 20 for detailed mechanical dimensions.

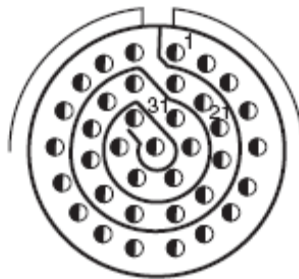

**Figure 4. Feedback Connector J3**

Resolver Connector Pinout			
Pin Number	Dual Resolver plus Encoder Configuration	Dual Encoder, No Resolver Configuration	Wire Gauge
1	Chassis Ground (Shield)	Chassis Ground (Shield)	22-28
2	Excitation A	Reserved	22-28
3	Excitation A Return	Reserved	22-28
4	Motor A Sin +	Analog In Spare 1+	22-28
5	Motor A Sin -	Analog In Spare 1-	22-28



6	Motor A Cos +	Analog In Spare 2+	22-28
7	Motor A Cos -	Analog In Spare 2-	22-28
8	Excitation B	Reserved	22-28
9	Excitation B Return	Reserved	22-28
10	Motor B Sin +	Analog In Spare 3+	22-28
11	Motor B Sin -	Analog In Spare 3-	22-28
12	Motor B Cos +	Analog In Spare 4+	22-28
13	Motor B Cos -	Analog In Spare 4-	22-28
14	Thermistor A	Thermistor A	22-28
15	Thermistor A Return	Thermistor A Return	22-28
16	Thermistor B	Thermistor B	22-28
17	Thermistor B Return	Thermistor B Return	22-28
18	+5 Out	+5 Out	22-28
19	Ground	Ground	22-28
20	Unused	Encoder B A	22-28
21	Unused	Encoder B A Rtn	22-28
22	Unused	Encoder B B	22-28
23	Unused	Encoder B B Rtn	22-28
24	Unused	Encoder B C	22-28
25	Unused	Encoder B C Rtn	22-28
26	Digital In 5+	Digital In 5+	22-28
27	Digital In 5-	Digital In 5-	22-28
28	Digital In 6+	Digital In 6+	22-28
29	Digital In 6-	Digital In 6-	22-28
30	+5 Out	+5 Out	22-28
31	Ground	Ground	22-28
32	Encoder A B	Encoder A B	22-28
33	Encoder A B Rtn	Encoder A B Rtn	22-28
34	Encoder A A	Encoder A A	22-28
35	Encoder A A Rtn	Encoder A A Rtn	22-28
36	Encoder A C	Encoder A C	22-28
37	Encoder A C Rtn	Encoder A C Rtn	22-28

## 5 System Interface (SI)

The System Interface (SI) is the main interface used in an end application. This interface includes low-level power and several networking and discrete I/O signals. Since the end use of the DRAGON is unknown, a generic interface has been provided to include the following:

- Low-Level Power (+28 Volts)
- Controller Area Network (CAN)
- RS422
- 2 Digital Outputs

- 4 Digital Inputs
- 1 Analog Input
- 28 VDC Fan Output

The SI also include service inputs that can be used for the following test and update functions:

- Connect to System with the HiDS
- Monitor the four Analog Test Points
- Inject an Analog Test Signal into the Unit
- Reprogram Internal Flash Memory

## **5.1 CAN**

The DRAGON includes a CAN physical interface compliant to the ISO 11898-2 specification. The maximum data rate is 1 Mbit/s for a bus length of 40 meters. The DRAGON CAN interface meets the extended common mode range of  $-7$  to  $+12$  volts. No internal bus termination is provided.

## **5.2 RS422**

The DRAGON includes an RS422 physical interface compliant to the TIA/EIA-422-B specification. The DRAGON is capable of a 1 Mbit/s data rate. The RS422 pins are short circuit protected from  $-7$  V to  $+12$  volts.

## **5.3 Digital Input/Outputs**

The DRAGON includes two digital inputs and well as two digital outputs. The I/O signals are standard differential RS422 signals compliant to the TIA/EIA-422-B specification. Internally, the digital I/O are controlled via a GPIO pin on the DSP.

## **5.4 Analog Input**

The DRAGON includes two analog inputs on the SI. These inputs may be configured through software as a control or test input. In a control mode, the signal may be used to give the DRAGON a torque or velocity command. In test mode, the signal may be used to inject a test signal into the system.

The analog input has a differential voltage input range of  $\pm 10$  Volts.

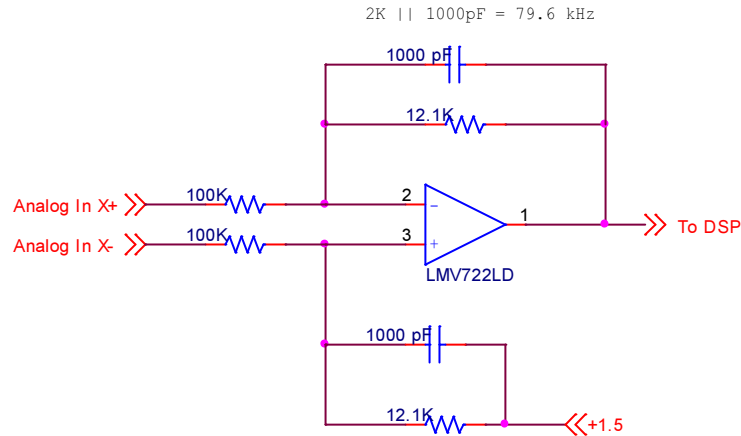

**Figure 5. Command Input Circuit**

**5.5 HiDS Interface**

The user may connect HiDS to the DRAGON with the service connector. The user may connect a standard USB port to the USB D+, USB D-, USB VBUS and USB GND for access to the HiDS functions.

**5.6 Analog Test Points**

The four analog test points are routed to the service connector for monitoring. The user may use the HiDS to setup the analog test points. The voltage range on the analog test points are +/- 2.5 volt. The test points are buffered from the system with a 100 Ohm resistor as can be seen in the figure below.

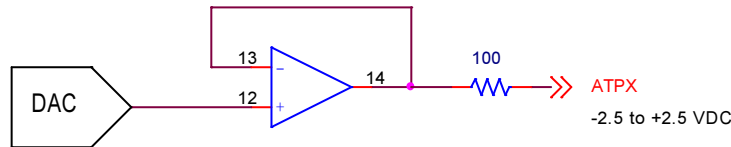

**Figure 6. Analog Test Point Output**

**5.7 Program Update**

The user may use the service interface to reprogram the internal FLASH memory. A flash update program is provided by ESIMotion.

**5.8 System Interface Connector J4**

The SI signals are routed to a 37-pin connector. The connector is type D38999/20FD35AN (insert arrangement 13-35). It accepts a size 22D pin (AWG wire size 22-28). The connections are pins and they mate with a socket-type connector, PN D38999/26FD35SN.

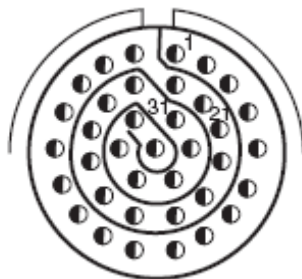

**Figure 7. System Interface Connector J4**

Pin Number	Description	Wire Gauge
1	Chassis Ground (Shield)	22-28
2	+28	22
3	+28	22
4	FAN	22-28
5	Digital In 3+	22-28
6	RS422 TX+	22-28
7	RS422 TX -	22-28
8	RS422 RX+	22-28
9	RS422 RX -	22-28
10	Digital In 1+	22-28
11	Digital In 1-	22-28
12	Digital In 2+	22-28
13	Digital In 2-	22-28
14	Analog Ground Ref	22-28
15	Analog In 1+	22-28
16	Analog In 1-	22-28
17	Analog In 2+	22-28
18	Analog In 2-	22-28
19	+28 Return	22
20	USB D+	22-28
21	USB D-	22-28
22	USB VBUS	22-28
23	USB GND	22-28
24	Digital In 3-	22-28
25	Spare	22-28
26	Spare	22-28
27	Analog Test Point 1	22-28
28	Analog Test Point 2	22-28
29	Analog Test Point 3	22-28

30	Analog Test Point 4	22-28
31	Digital Out 1+	22-28
32	Digital Out 1-	22-28
33	Digital Out 2+	22-28
34	Digital Out 2-	22-28
35	CAN+	22-28
36	CAN-	22-28
37	+5 Out	22-28

## 6 Connector Summary

Function	J	Description	Vendor	Dragon Connector	Mate to Connector	Mating Contact (contacts included with connectors)
Motor Feedback Connector	J3	WALL MOUNT RECEPTACLE, 38999 SIII, A Key	Interstate Connecting Components Inc.	D38999/20FD35AA	D38999/26FD35SA	MS27488-22-2
System Interface Connector	J4	WALL MOUNT RECEPTACLE, 38999 SIII, Normal Key	Interstate Connecting Components Inc.	D38999/20FD35AN	D38999/26FD35SN	MS27488-22-2
Motor Connector	J2	NARROW FLANGE RECEPTACLE, MIL-C-26482 SII	Interstate Connecting Components Inc.	MS3470L24-19S	MS3476L24-19P	M39029/4-113
Power Connector	J1	Box Mt. Recept Cad Od Alum	Interstate Connecting Components Inc.	MS3452L16-10P	MS3456L16-10S	M39029/30/219

## 7 Conclusion

This document outlines the Hardware Interface Description (HIF) for the DRAGON servo system.