

600 Volt, 35 Amp Dragon Series 3-Phase Power Module

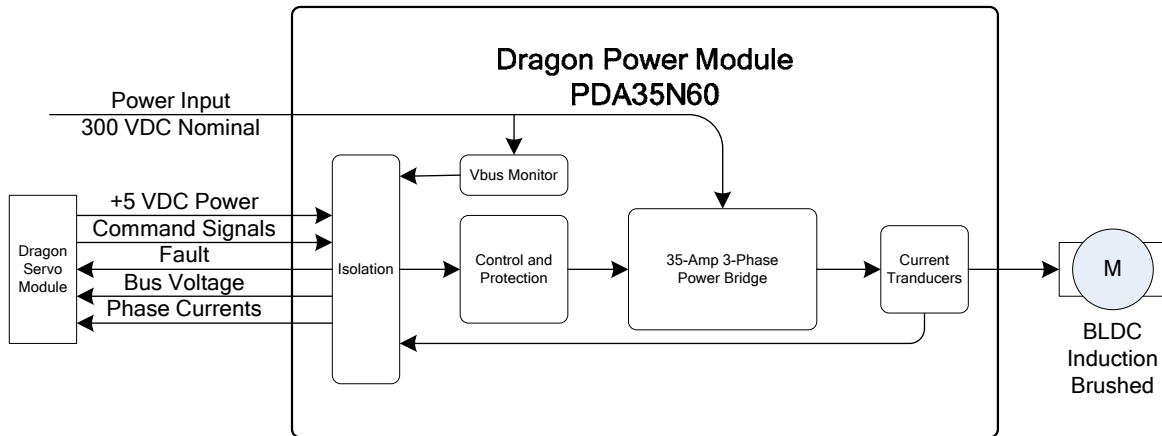

Small, ruggedized 6 kW motor drive module for 300 Volt applications

Features:

- Small Size: 2.5" x 3.33" x 1.5"
 - **500W / in³ – 30W/cm³**
 - Only 0.375" wider than a credit card
 - Ideal for liquid or chassis cooled systems
- Highly Integrated
 - Short-Circuit Protection
 - Bus Voltage Monitor
 - 3-Phase Current Sensing
 - Temperature Monitor
 - Electrical Isolation
 - Built-In-Test with Fault Output
- High Performance
 - Low Loss IGBT
 - > 20 kHz Operation
- High Power
 - Up to 6kW of continuous output power
- Flexible Configuration
 - BLDC Motors
 - Induction Motors
 - DC Brushed Motors
- Seamless integration with ESI's Dragon Servo Control Module (DRA1000)

Rating Summary:

Item	Units	Value	Notes
Max Bus Voltage	V	600	
Phase Current	A	33	Heatsink Temperature = 80°C (45 Amps @ 25°C)
Ambient Temperature	°C (°F)	-50 to 100 (-58 to 212)	Non-Operational
		-40 to 70 (-40 to 160)	Operating
Vibration	g	10.0	20 Hz – 2000 Hz
Mechanical Shock	G	40	Non-Operating, Half Sine, 11 mS
		20	Operating, Half Sine, 11 mS
Volume	ln^3	12.5	2.5" x 3.33" x 1.5"



Figure 1 – Dragon Power Module